



9550 VEHICULAR SLIDE GATE OPERATOR



large gates
up to 10,000 Lbs



electrically
released brake

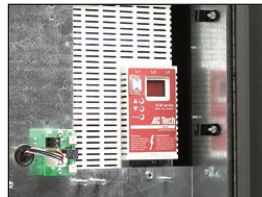

solid-state
variable speed control



partial open
user adjustable

- User adjustable variable speed control from 1/2 ft/sec up to 4 ft/sec
- Slow-start / slow-stop operation
- Self-adjusting disc brake with manual release
- Direct driven limit switches for precise gate control
- Anti-tailgating and partial open features to help control unauthorized vehicle access
- Ports for plug-in loop detectors
- 115 VAC convenience outlets
- Built-in power switch

FEATURES

ACCESS CONTROL **SOLUTIONS**





9550 VEHICULAR SLIDE GATE OPERATORS

The DKS model 9550 vehicular slide gate operator is designed for use on very large and very heavy gates in maximum security applications only. This operator features a solid-state speed control module that starts and stops the gate slowly. The self-adjusting disc brake system stops the gate precisely at its limit settings. The operating speed of the gate is user adjustable (up to 4-ft/sec) making this operator ideal for security sensitive areas where perimeter security must be maintained.

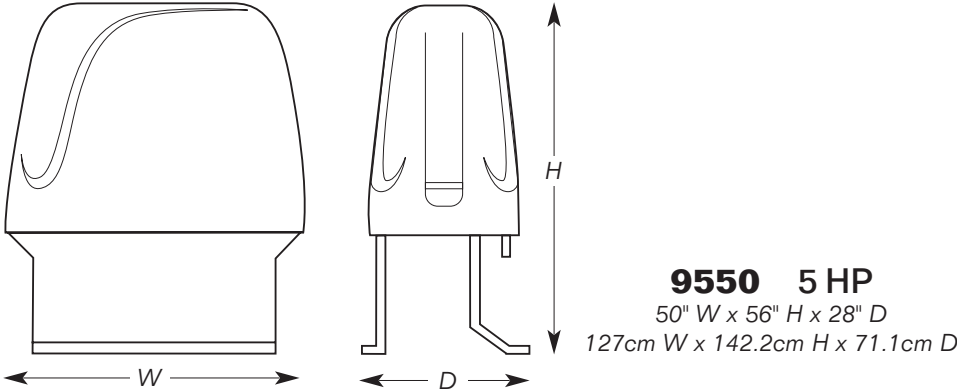

9550 Specs

Class of operation	Max Gate Length *	Max Gate Weight *	HP	Power 3-Phase
III (Limited), IV (Restricted)	160 Ft (48.7 m)	10000 Lbs. (4536 kg)	5HP	230 VAC, 60 Hz, 12.4 A 460 VAC, 60 Hz, 6.2 A

* Assumes gate to be level and in good operating condition.

General Specs

Mechanical

3/8" Steel frame.
1/4" polyethylene molded cover
Primary reduction: 10:1 heavy-duty gear reducer running in a continuous oil bath
Chain: #60 roller chain
Speed: Adjustable from 1/2 to 4 feet/sec.
Brake: Spring-set, electrically released, self adjusting disc brake with manual release

Operator kit

Includes chain brackets, hardware, and 20-foot (6 m) of #60 chain

Note

This vehicular slide gate operator is designed for Class III and IV applications only and should never be used in applications serving the general public such as apartment complexes, gated communities, residential applications, parking garages, etc.

Non-contact sensors (type B1) must be used with this gate operator product.

Advanced Features

Adjustable speed control circuit, 1/2' to 4'/sec
Slow start / slow stop
Adjustable partial open
Anti-tailgating
Selectable stop / reverse loop function
Direct driven limit switches
Built-in power switch
Warn-before-operate function
Port for plug-in loop detectors (DKS Detectors only)
Two 115 VAC Convenience outlets

Options

Gate Tracker reporting provides operator data to a companion DKS access control system (models 1833, 1835, 1837 and 1838).

Red/Green traffic signal provides a visual indication when the gate is safe and it is OK for traffic to proceed.

Operating Temp

10°F to 140°F
-12°C to 62°C
Optional heater kit recommended for colder environments

Shipping Weight

Approximately 900 lbs (408 kg)

Warranty

2-year limited factory warranty

Distributed by:

DOORKING®, INC.

120 Glasgow Avenue, Inglewood, California 90301 U.S.A. Tel: 310-645-0023 FAX: 310-641-1586 www.doorking.com

© 2007 All Rights Reserved. Product specifications may change without notice. Rev. 3/07

MEMBER:

