



9310 VEHICULAR SLIDE GATE OPERATOR



entrapment
prevention system
reverses gate on contact



fail-safe release
Never be locked out (or in)
of your property



built in
power and reset switches

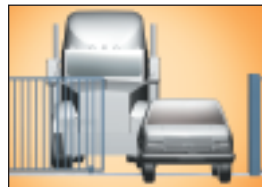

partial open
allows long gates to open 14
feet for automobile traffic, or
opens gate fully for large trucks
or oversized vans

- Direct driven limit nuts for precise gate control and eliminates secondary chains and sprockets
- Safety – built-in electronic reverse system
- Special anti-tailgating feature helps to reduce unauthorized vehicle access
- Advanced microprocessor control board features programming switches to set the mode of operation required and has ports for DKS plug-in loop detectors to simplify wiring
- Built-in operator diagnostics
- Convenience outlets for accessory transformers
- Attractive 1/4 inch polyethylene cover
- G90 galvanized steel frame prevents rusting
- This operator meets or exceeds the requirements of the UL 325 and UL 991 safety standards and is ETL Listed
- 5-year limited warranty

FEATURES

ACCESS CONTROL SOLUTIONS





9310 VEHICULAR SLIDE GATE OPERATOR

The DKS 9310 series of slide gate operators offer convenience, reliability and safe operation in a small, compact design. These operators are ideally used in residential, commercial or industrial high-use applications. The innovative fail-safe design of these operators significantly reduces the chance of injury or entrapment and makes these operators the safest slide gate operators in the market today! Designed with versatility in mind, the 9310 can be configured for front, center or rear drive applications and can be configured for front, center or rear drive applications and can be pad or post mounted.

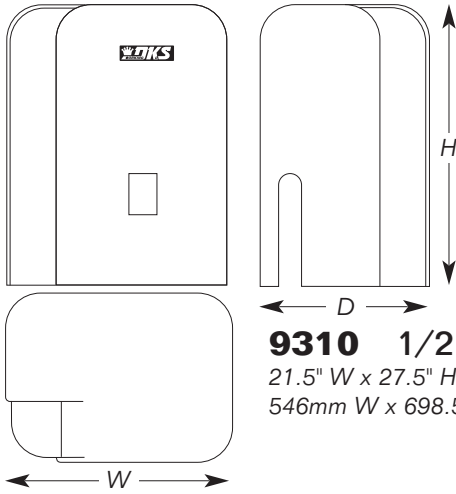

9310 1/2 HP
21.5" W x 27.5" H x 16.5" D
546mm W x 698.5mm H x 419mm D

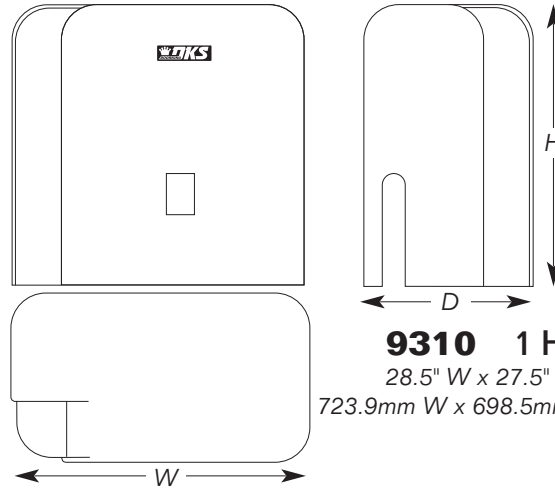

9310 1 HP
28.5" W x 27.5" H x 16.5" D
723.9mm W x 698.5mm H x 419mm D

9310 1/2 HP Specs

Class of operation	Max Gate Length *	Max Gate Weight *	HP	Power	Convenience Open Package
I, II, III, IV	30 Ft (9.1 m)	1000 Lbs. (453.6 kg)	1/2 HP 60 cycles/hr continuous duty	115 VAC, 60 Hz, 5.4A 230 VAC, 60 Hz, 2.7A** 208 VAC, 60 Hz, 2.7A** 460 VAC, 60 Hz, 1.4A**	Optional

9310 1 HP Specs

Class of operation	Max Gate Length *	Max Gate Weight *	HP	Power	Convenience Open Package
I, II, III, IV	45 Ft (13.7 m)	1500 Lbs. (680.3 kg)	1HP 60 cycles/hr continuous duty	115 VAC, 60 Hz, 9.7A 208/230 VAC, 60 Hz, 4.9A** 208/230 VAC, 60 Hz, 2.8A 3Ø 460 VAC, 60 Hz 1.3A 3Ø	Optional

* Assumes gate to be in good condition and must be on a level surface.
When combined with convenience open option, 1/2HP max weight is 800 Lbs., and 1300 Lbs. with 1HP.
** These operators use a step-down transformer, to achieve 115 VAC operating voltage.

General Specs

Mechanical

Primary Reduction: 10:1 worm
Chain: #40
Speed: Approximately 10 in/sec (254 mm/sec)
Cover: 1/4 inch polyethylene
Frame: G90 Galvanized steel to prevent rusting

Manual Release

Fail Safe: Push gate open
Fail Secure: Keyed release optional

Operator kit

includes chain brackets, hardware, and 20-foot (6 m) of #40 chain

Advanced Features

Adjustable partial open limit
Power start boost circuit (1/2 HP only)
Direct driven limit nuts for precise gate control
Auto-close timer 1-23 sec.
Selectable loop function-stop or reverse
Timer override feature helps prevent tailgating
Automatically assumes fail-safe mode when an entrapment condition exists
Built-in operator diagnostics
Gate Tacker reporting output provides operator data to access control system (DKS systems with card access only)
Power and alarm reset switches
Ports for plug-in open and reverse loop detectors. DKS plug-in detectors only
Convenience outlets for plug-in accessory transformers

Safety Standards

Complies with the UL 325 and UL 991 safety standards
ETL listed

Operating Temp

10°F to 140°F
-12°C to 62°C
Heater kit recommended for colder environments

Shipping Weight

Approximately 130-150 lbs (31.8 kg)

Warranty

5-year limited factory warranty

Distributed by:

DOORKING®, INC.

120 Glasgow Avenue, Inglewood, California 90301 U.S.A. Tel: 310-645-0023 FAX: 310-641-1586 www.doorking.com

© 2006 All Rights Reserved. Product specifications may change without notice. Rev. 4/06

MEMBER:

